

2

1

B

B

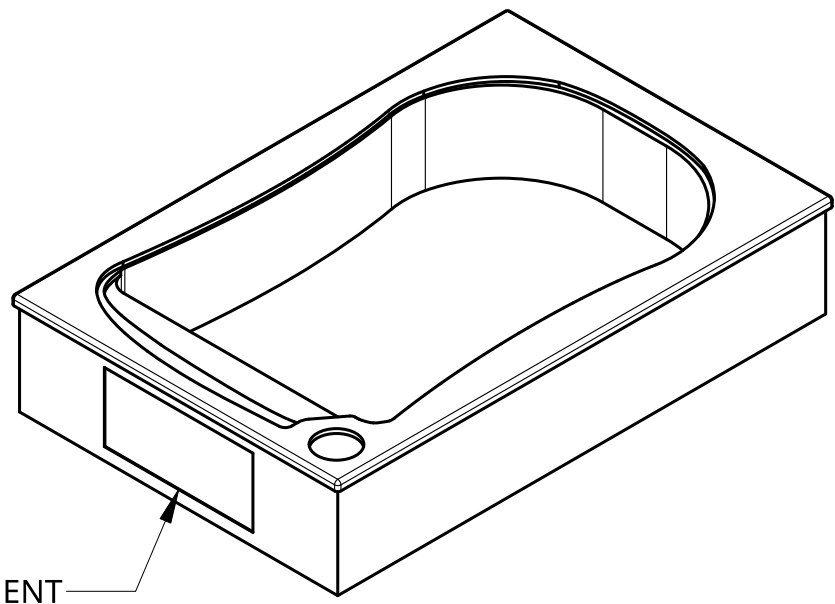
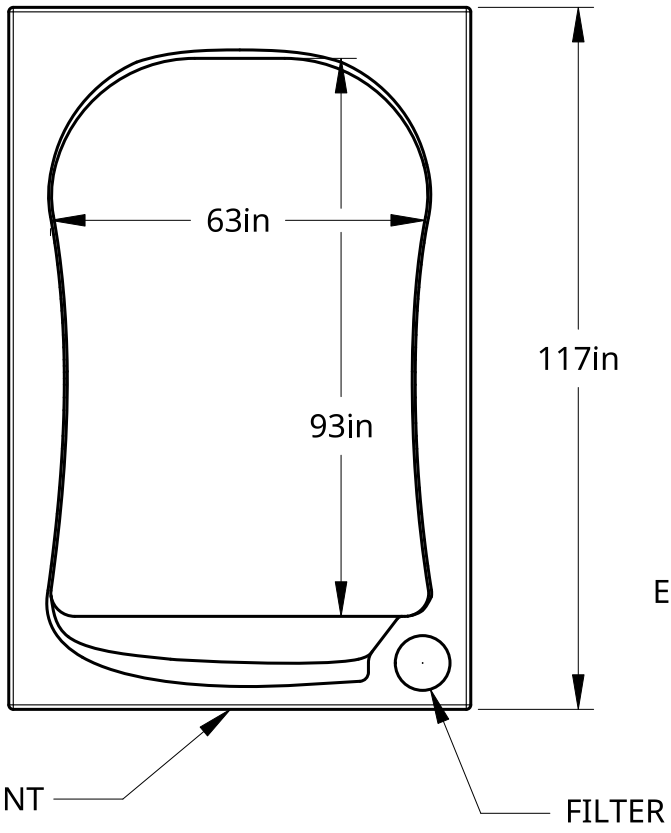

Notes:

- 1. MUST BE PLACED ON HARD LEVEL SURFACE
- 2. ALL WORK MUST BE DONE TO LOCAL CODE/ORDINANCES
- 3. EQUIPMENT CAN BE LOCATED IN DIFFERENT LOCATIONS - CONSULT ROYAL SPA REP
- 4. PROPER IN ROOM HVAC WILL NEED TO BE INSTALLED TO ACCOMMODATE FOR HUMIDITY FROM OPEN TANK

Electrical Requiements:

- 1. 220V 20AMP, 3 WIRE WITH GROUND, GFI PROTECTED
- 2. HUBBLE L14-30 RECEPTICLE OR EQUIVALENT

A

A

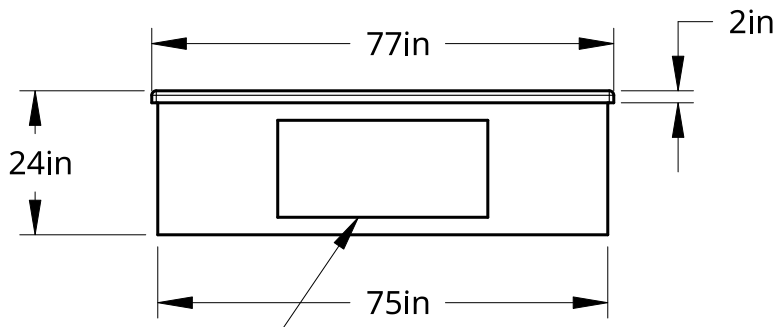

EQUIPMENT



TITLE			
FLOAT ROOM			
SIZE	DWG NO.	REV.	
A			
SCALE	WEIGHT	SHEET	1 of 1
1:32			

2

1